



*Owner's Installation Guide for the*  
***Paxton Automotive***  
***2005 Ford 4.6L Mustang GT (3-Valve)***  
***Charge Cooler Upgrade***  
*P/N: 1300005*

**Paxton Automotive . 1300 Beacon Place . Oxnard CA 93033**  
**805 604-1336 . FAX • 805 604-1337**

# FOREWORD

---

**P**roper installation of this supercharger kit requires general automotive mechanic knowledge and experience. Please browse through each step of this instruction manual *prior* to beginning the installation to determine if you should refer the job to a professional installer/technician. Please call Paxton Automotive for installers in your area.

© 2005 PAXTON AUTOMOTIVE

*All rights reserved. No part of this publication may be reproduced, transmitted, transcribed, or translated into another language in any form, by any means without written permission of PAXTON AUTOMOTIVE.*

# TABLE OF CONTENTS

---

<b>FOREWORD</b> .....	<i>.ii</i>
<b>TABLE OF CONTENTS</b> .....	<i>.iii</i>
<b>NOTICES</b> .....	<i>.iv</i>
<b>TOOL &amp; SUPPLY REQUIREMENTS</b> .....	<i>.v</i>
<b>PARTS LIST</b> ( <i>2005 Mustang GT, Charge cooler upgrade</i> ) .....	<i>.vi</i>
<b>1. PREPARATION AND REMOVAL</b> .....	<i>.1-1</i>
<b>2. SUPERCHARGER RECLOCKING AND REINSTALLATION</b> .....	<i>.2-1</i>
<b>3. CHARGE AIR COOLER INSTALLATION</b> .....	<i>.3-1</i>
<b>A. BUMPER COVER AND SPLASH PAN</b> .....	<i>.3-1</i>
<b>B. CHARGE AIR COOLER ASSEMBLY</b> .....	<i>.3-4</i>
<b>C. COMPRESSOR BYPASS VALVE ASSEMBLY INSTALLATION</b> .....	<i>.3-6</i>
<b>D. WIRING HARNESS RELOCATION</b> .....	<i>.3-10</i>
<b>E. ENGINE COOLANT RESERVOIR INSTALLATION</b> .....	<i>.3-11</i>
<b>4. AIR INLET ASSEMBLY</b> .....	<i>.4-1</i>
<b>5. FINAL CHECK</b> .....	<i>.5-1</i>

# NOTICES

## **(Read before installation is started)**

Included in this kit is a smaller than originally supplied supercharger pulley. This new pulley is recommended to achieve the best performance results. Removal of the factory sealed pulley will reduce the supercharger warranty from three years to one year unless the supercharger unit (with the original pulley still attached) and new pulley are sent into Paxton for removal, installation and re-sealing. If the supercharger warranty is not a concern or if the supercharger warranty has expired, the pulley may simply be removed and replaced with the new part supplied. Hammering/prying etc. on the supercharger and/or pulley will cause damage to the parts. Light heating of the supercharger pulley with a propane torch (if the pulley is tight on the shaft) will aid removal. A return authorization number is required before the supercharger and pulley are sent into Paxton. Call the Paxton service department at (805) 487-3796 for a return authorization number. Return freight (ground) will be paid by Paxton.

This product is protected by state common law, copyright and/or patent. All legal rights therein are reserved. The design, layout, dimensions, geometry, and engineering features shown in this product are the exclusive property of Paxton Automotive. This product may not be copied or duplicated in whole or part, abstractly or fundamentally, intentionally or fortuitously, nor shall any design, dimension, or other information be incorporated into any product or apparatus without prior written consent of Paxton Automotive.

### **PLEASE READ CAREFULLY**

This kit should only be installed by qualified mechanics. **It is imperative that the correct air/fuel mixture be maintained at all times. This Kit is to be supplied to competent engine tuners for their completion by the addition of custom tuning.** The installation of this system without custom tuning to compensate for boost pressure will **cause engine damage.**

This product is intended for use on healthy, well maintained engines. Installation on a worn-out or damaged engine is not recommended and may result in failure of the engine.

**Paxton Automotive is not responsible for engine damage.** Installation on new engines will not harm or adversely affect the break-in period so long as factory break-in procedures are followed.

***For best performance and continued durability, please take note of the following key points:***

1. Use only premium grade fuel 91 octane or higher (R+M/2).
2. The engine must have stock or lower than stock compression ratio.
3. If the engine has been modified in any way, check with Paxton prior to using this product.
4. Always listen for any sign of detonation (pinging) and discontinue hard use (no boost) until problem is resolved.
5. Perform an oil and filter change upon completion of this installation and prior to operating the vehicle. Thereafter, always use a high grade "SF" rated engine oil or a high quality synthetic, and change the oil and filter every 3000 miles.

*This product may not be legal for use on public roads in all 50 states.*

# PAXTON CHARGE COOLER Installation Instructions

## 2005 Ford 4.6 Mustang GT (3-Valve)

---

**Before beginning this installation,  
please read through this entire instruction booklet**

This Paxton Air/Air Charge Cooler system was designed as a street/strip oriented charge cooler, specifically for use on 2005 Ford 4.6 Mustang vehicles equipped with a Paxton supercharger.

As with any power enhancing product, this system is intended for use on healthy, well-maintained engines. *Paxton Automotive is not responsible for engine damage.* Installation on new vehicles will not harm or adversely affect the break-in period so long as factory break-in procedures are followed.

---

### **TOOL & SUPPLY REQUIREMENTS:**

- Open End Wrenches: SAE and Metric
- Allen Wrenches: SAE
- Flat #2 Screwdriver
- Phillips #2 Screwdriver
- Wire Cutters, Strippers and Crimpers
- Tape Measure
- Pipe Tape (Teflon)
- Adjustable Wrench
- 7/8" Hole Saw
- Tap - 5/16-18
- 1/2" Drive Ratchet
- 3/8" Drive and Socket Set: SAE and Metric
- 9/16" Box end Ratchet Wrench (*highly recommended*)



# 2005 Mustang GT, H.O. Upgrade

Part No. 1300005

## PARTS LIST

**IMPORTANT:** Before beginning installation, verify that all parts are included in the kit. Report any shortages or damaged parts immediately.

PART NO.	DESCRIPTION	QTY.	PART NUMBER	DESCRIPTION	QTY.
2A036-348	S/C PULLEY 3.48" 6-GROOVE	1			
5A001-025	DIABLE MAFia, '05 MUS	1			
8R101-001	PULLEY RETAINER ASY 6-RIB	1			
2A040-011	PULLEY RETAINER S/C	1			
7B372-110	3/8-24 x 1" GRADE 8 HXHD	1			
7K375-040	3/8"AN960 FLAT WASHER PLATED	1			
7U100-070	KEY, 3/16" SQUARE x 7/8" LONG	1			
4809655	MANUAL, H.O. UPGRADE	1			
8PN201-050	CAC ASSY, '05 GT AIR/AIR	1			
8PN101-050	WELDED CORE ASSY, '05 MUS GT	1			
4PFU012-021	DISCH DUCT, T/B '05 MUSTANG	1			
4PFU012-030	CAC TUBE, "A" '05 MUS GT	1			
4PFU012-040	CAC TUBE, "B" '05 MUS GT	1			
4PFU012-050	CAC TUBE, "C" '05 MUS GT	1			
4PFU012-060	CAC TUBE, "D" '05 MUS GT	1			
4PFU012-070	CAC TUBE, "E" '05 MUS GT	1			
7PS300-301	BUMP HOSE, Ø3.00" x 3.00"L	3			
7PS300-300	SLEEVE, BLACK, Ø3.00" x 3.00"L	2			
7R002-048	#48 SAE TYPE "F" SS HOSE CLAMP	14			
7R002-072	#72 SAE TYPE "F" SS HOSE CLAMP	2			
7S300-003	RUBBER ELBOW 3" MODIFIED	2			
7PS450-200	SLEEVE, BLACK Ø4.5" x 2.0"L	1			
2A017-036	SPACER, PLTBGRHSG, 0186"	4			
7C080-035	M8 x 125 x 35 BLT CL88	4			
7F008-020	NUT, M8 x 125	4			
7J312-000	5/16" FLAT WASHER-SAE	10			
7R002-044	#44 SAE TYPE "F" SS HOSE CLAMP	1			
7A312-050	5/16-18 x 1/2" HXHD GR5, ZINC	2			
8PN010-030	SUPPRT, '05 MUST COOLR DUCT, ZN	2			
7R002-016	#16 SAE TYPE "F" SS HOSE CLAMP	8			
7P156-082	5/32" TEE	2			
7U030-046	5/32" VACUUM LINE	8'			
8D001-001	STD COMPRESS BYPASS VALVE	2			
7U133-100	HOSE, ELBOW, 90°, 1"ID, MOLDED	1			
7U034-016	1" GS HEATER HOSE	25'			
7P750-100	3/4"NPT x 1" HOSE FITTING	1			
7P218-156	VAC TEE, 7/32", 7/32", 5/32"	1			
7U100-055	TIE-WRAP, 7.5" NYLON	4			
7P750-100	3/4"NPT x 1" HOSE FITTING	1			
8N155-080	COOLANT RES RELOC, '05 MUST	1			
8N055-080	TANK, RAD OVERFLOW, '05 MUST	1			
4FU010-051	MTG BRKT "A", RES RELOC '05 MUST	1			
4FU010-061	BRKT "B", COOL RES RELOC '05 MUST	1			
7A250-051	1/4-20 x 50 HHCS ZINC PLTD	4			
7P250-045	1/4" MALE NPT x 3/8" MALE BARB	1			
7J006-093	6mm WASHER, PLATED	4			
7R002-010	#10 SAE TYPE "F" SS HOSE CLAMP	1			
7P375-050	3/8" HOSE UNION, BRASS	1			
7U030-056	3/8" PCV/VAC RUBBER HOSE	2.5'			
7R004-002	STEPLESS CLAMP, 170-70	3			
7C060-020	M6 x 10 x 20mm HHCS ZN	3			
7J006-093	6mm WASHER, PLATED	3			
7PS275-100	SLEEVE, 2.75"ID x 1"	1			

---

# Section 1

## PREPARATION AND REMOVAL

---

### 1. PREPARATION AND REMOVAL

- A. Disconnect the battery.
- B. Remove the six nylon clips retaining the upper radiator core support cover. (See Fig. 1-a.)

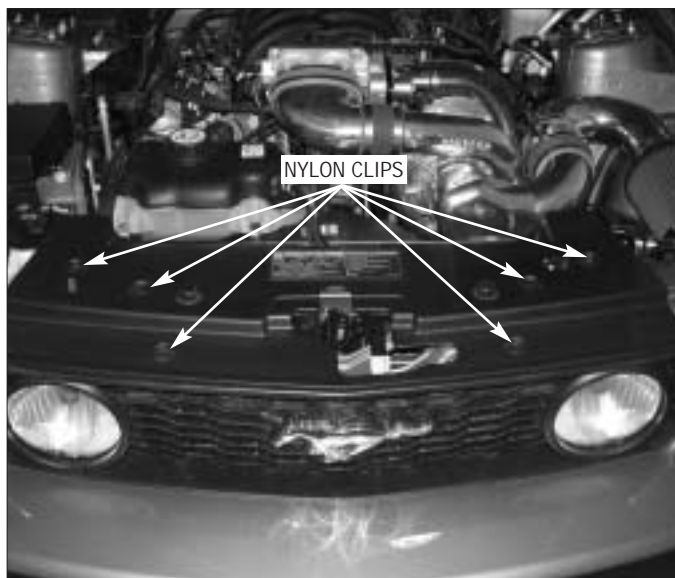

Fig. 1-a

- C. Loosen the four hose clamps securing the supercharger discharge tube from the supercharger to the throttle body. Disconnect the by-pass valve hoses where they connect to the inlet and discharge tubes. Disconnect the by-pass valve vacuum line where it connects at the fuel rail. Set the by-pass valve aside to be reinstalled in a later step. Remove the discharge tube and set it aside. It will not be reused.
- D. Unplug the MAF connection from the meter. Loosen the hose clamps securing the inlet ducts to the supercharger and inlet duct support bracket. Remove the inlet duct assembly and set it aside to be reinstalled in a later step
- E. Disconnect the oil feed and oil drain lines.

---

\*\*\* NOTE \*\*\*

*Temporarily cap the oil lines to protect your engine from foreign particles.*

---

- F. Using a 1/2" ratchet wrench loosen the accessory belt tensioner and remove the belt from the supercharger pulley only. Tie the belt back away from the supercharger temporarily.
- G. Remove the five 9/16" headed screws securing the supercharger to its mounting plate.

---

\*\*\* NOTE \*\*\*

*A 9/16" ratchet wrench will greatly aid in this step.*

---

- H. Remove the supercharger from the vehicle.

- I. Locate the coolant drain plug on the passenger side of the radiator. Next drain the coolant into a clean container. This coolant will be reused in a later step.
- J. Remove the two 8mm headed bolts securing the coolant overflow reservoir to the plastic fan shroud. (See Fig. 1-b.)
- K. Disconnect the small overflow hose (running across the top of the radiator) from the overflow reservoir. (See Fig. 1-b.)

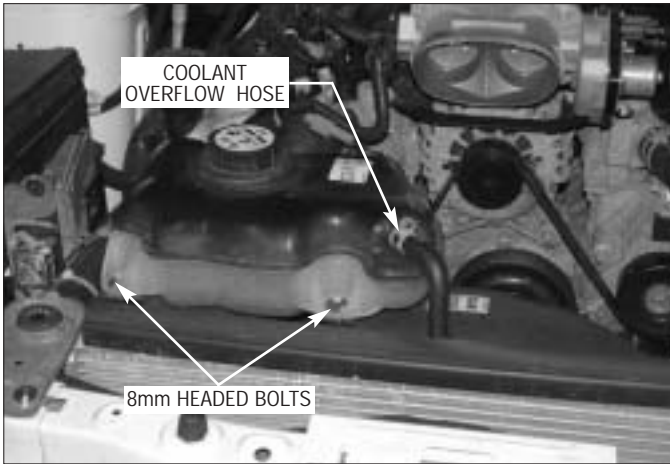

Fig. 1-b

- L. Remove the large hose connecting the thermostat hose to the bottom of the overflow reservoir. The hose and overflow reservoir will not be reused. (See Fig. 1-c.)

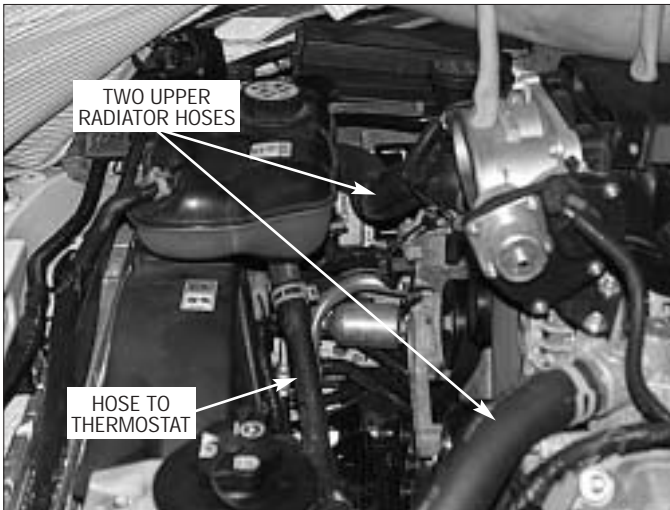

Fig. 1-c

**\*\*\* NOTE \*\*\***

*Retain only the fill cap for reuse.*

# Section 2

## SUPERCHARGER RECLOCKING AND REINSTALLATION

### 2. SUPERCHARGER RECLOCKING AND REINSTALLATION

- A. Place the supercharger on a clean flat surface with the drive pulley facing up.
- B. Loosen and remove the six 1/4-20 cap screws and retaining plates that hold the compressor housing to the gearcase.
- C. Carefully rotate the supercharger volute to the specified location as shown. (See Fig. 2-a.)

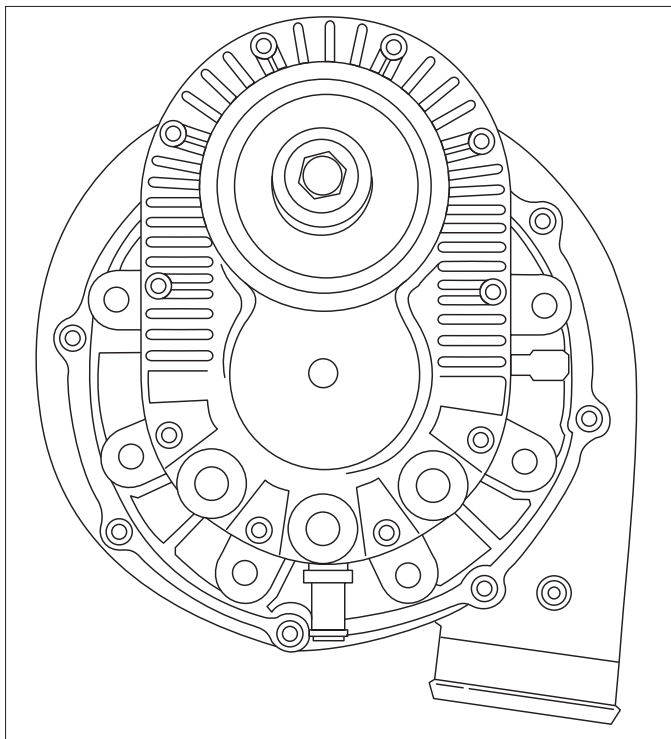

Fig. 2-a

- D. Evenly retighten the six (6) cap screws, torque to 60 in/lbs (5ft/lbs).
- E. Remove original 3.80" supercharger pulley from the supercharger and install the supplied 3.48" pulley.

**\*\*\* NOTE \*\*\***

*Included in this kit is a smaller than originally supplied supercharger pulley. This new pulley is recommended to achieve best performance results. Removal of the factory sealed pulley will reduce the supercharger warranty from three years to one year unless the supercharger unit (with the original pulley still attached) and new pulley are sent into Paxton for removal, installation and re-sealing. If supercharger warranty is not a concern or if the supercharger warranty has expired, the pulley may simply be removed and replaced with the new part supplied. Hammering/prying etc. on the supercharger and/or pulley will cause damage to the parts. Light heating of the supercharger pulley with a propane torch (if the pulley is tight on the shaft) will aid removal. A return authorization number is required before the supercharger and pulley are sent into Paxton. Call the Paxton service department at (805) 604-1336 for return authorization number. Return freight (ground) will be paid by Paxton.*

**\*\*\* NOTE \*\*\***

*If the compressor housing does not rotate freely relative to the gearcase, DO NOT FORCE IT. SERIOUS SUPERCHARGER DAMAGE MAY OCCUR. The machined mating surfaces are designed to prevent pressurized air from escaping and have minimal tolerances. If the housing will not move or is very tight, contact Paxton Automotive immediately at (805) 604-1336 and ask for our service department for further assistance.*

## 2. SUPERCHARGER RECLOCKING AND REINSTALLATION, cont'd

- F.** Remove the 3.5" plastic idler, retainer and washer. Carefully reposition the idler and its two spacers to the lower mounting hole just below its current position. Reinstall the retainer previously removed and tighten. (See *Fig. 2-b.*)

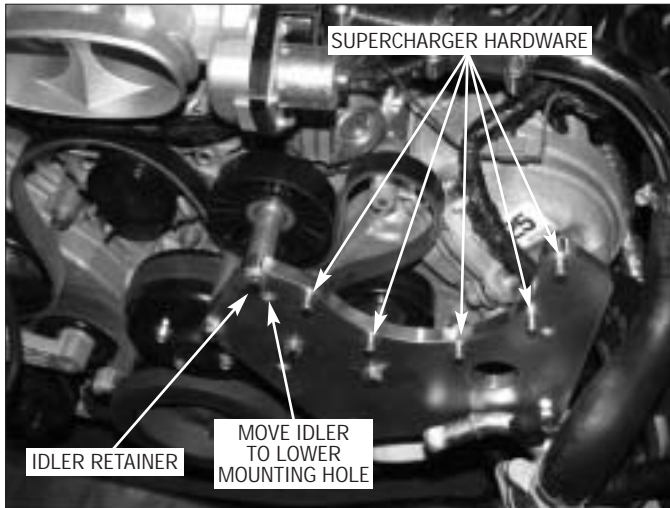

*Fig. 2-b*

- G.** Install the five 3/8-16 x 1.0" bolts and washers through the back side of the mounting plate. (See *Fig. 2-b.*)
- H.** Secure the supercharger assembly to the mounting plate using the previously installed hardware. A 9/16" ratcheting end wrench will greatly aid this step.
- I.** Secure the oil drain hose to the installed brass fitting in the oil pan, making sure to route in a smooth downward manner away from moving or hot objects.

**\*\*\* NOTE \*\*\***

*Any dips, "uphill" sections, kinks or restrictions may cause drainage problems and possible supercharger failure.*

- J.** Attach the -4 oil feed hose to the straight -4 fitting installed in the supercharger. Secure away from moving or hot objects.
- K.** Using a 1/2" ratchet, rotate the factory spring tensioner clockwise and install the accessory drive belt. Refer to *Fig. 2-c* for proper belt routing.

## 2. SUPERCHARGER RECLOCKING AND REINSTALLATION, cont'd

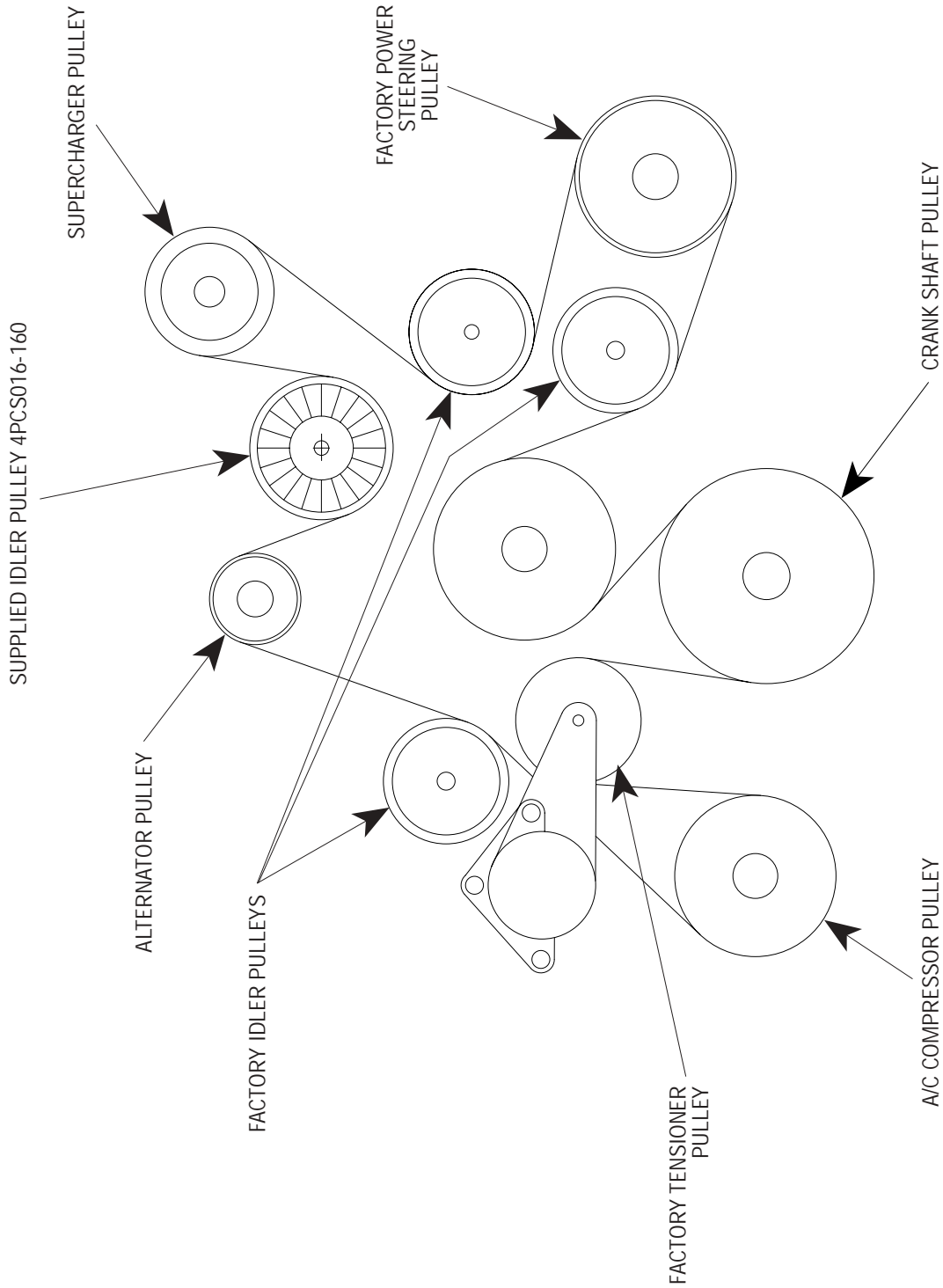

Fig. 2-c / Belt routing

*This Page Left Intentionally Blank*

# Section 3

## CHARGE AIR COOLER INSTALLATION

### 3. CHARGE AIR COOLER INSTALLATION

\*\*\* NOTE \*\*\*

For non-cooled kits skip this section and proceed to Section 9.

#### A. BUMPER COVER AND SPLASH PAN

1. Raise the vehicle with a floor jack and set on jack stands.
2. Remove the seven 5.5mm headed screws retaining the lower splash panel. (See Fig. 3A-a.)

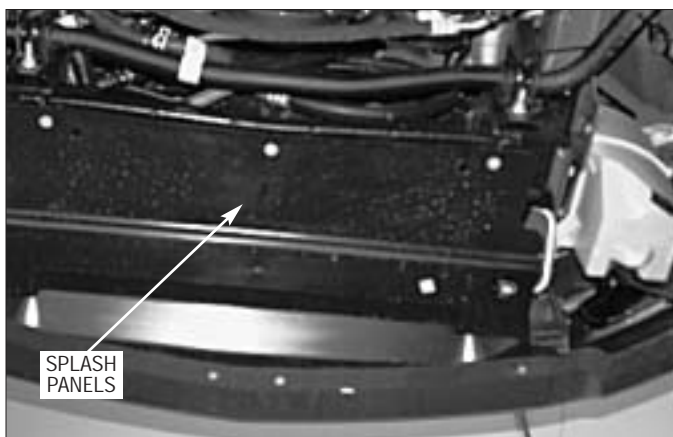

Fig. 3A-a

3. Remove the six Phillips-head screws (3 each side) on the lower portions of the plastic inner fender liners. (See Fig. 3A-b.)

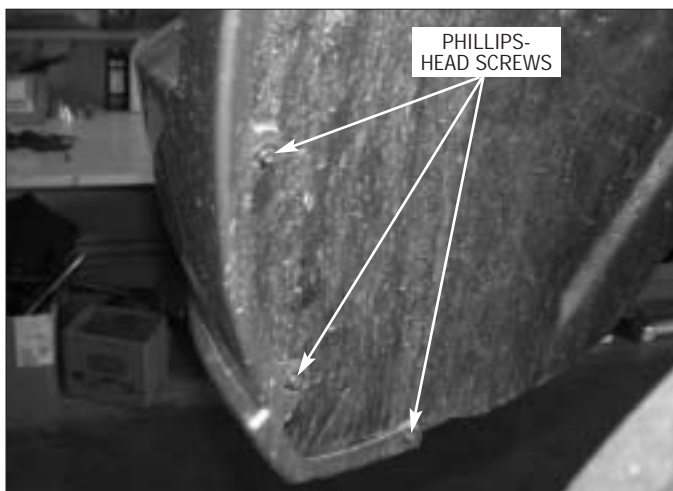

Fig. 3A-b

4. Remove the five plastic clips securing the front portion of the fender liner. Both sides need to be removed. (See Fig. 3A-c.)



Fig. 3A-c

5. Remove the four 10mm nuts (2 each side) retaining the bumper cover to the fenders. (See Fig. 3A-d.)

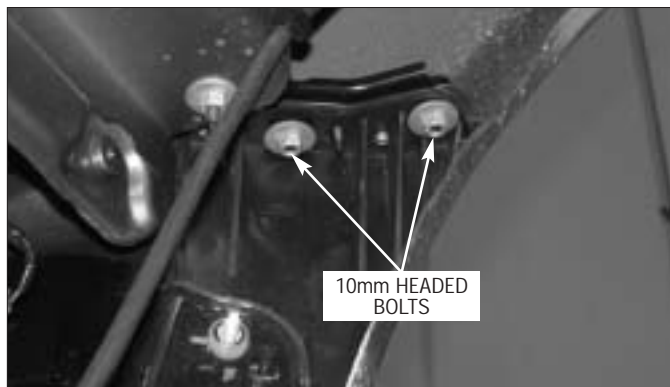

Fig. 3A-d

### 3. CHARGE AIR COOLER INSTALLATION, cont'd

6. Disconnect the connectors on the parking and the lower fog lights. (See Fig. 3A-e.)

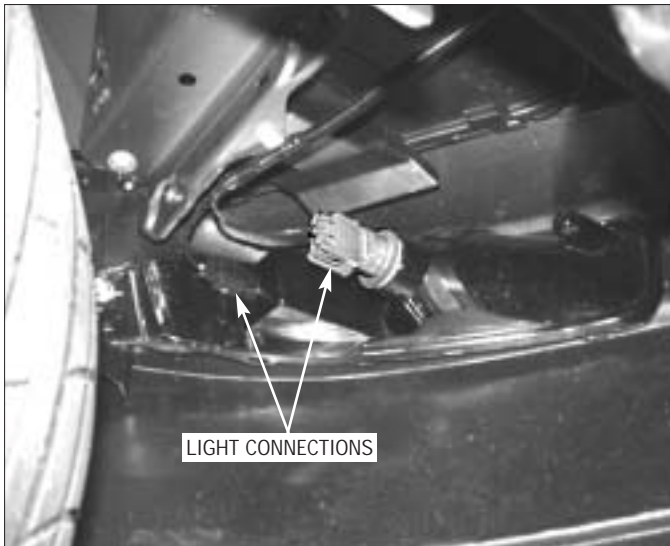

Fig. 3A-e

7. Remove the six nylon clips retaining the upper radiator core support cover. (See Fig. 3A-f.)

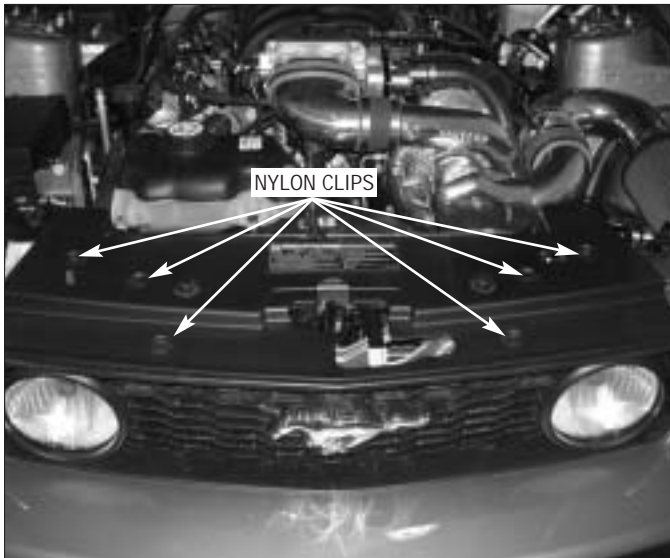

Fig. 3-f

8. Remove the two 10mm headed bolts (1 each side upper portion of grill). (See Fig. 3A-g.)



Fig. 3A-g

9. Lift up on the tabs releasing them from the clips. (See Fig. 3A-h.)

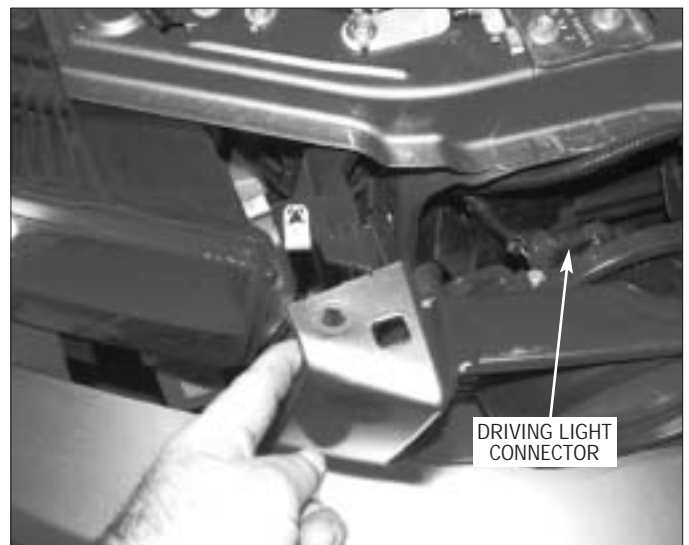

Fig. 3A-h

10. Pull out on the bumper cover
11. Remove the connectors to the driving lights in the grill. (See Fig. 3A-h.)
12. Remove the bumper cover and set aside. (See Fig. 3A-i.)

### 3. CHARGE AIR COOLER INSTALLATION, cont'd

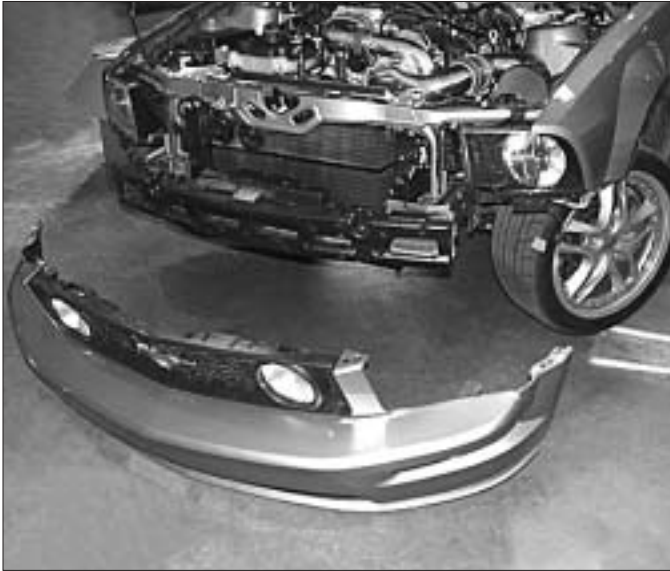

Fig. 3A-i

13. Remove four nylon push pins from the styrofoam bumper support and set the support and the pins aside to be reinstalled. (See Fig. 3A-j.)

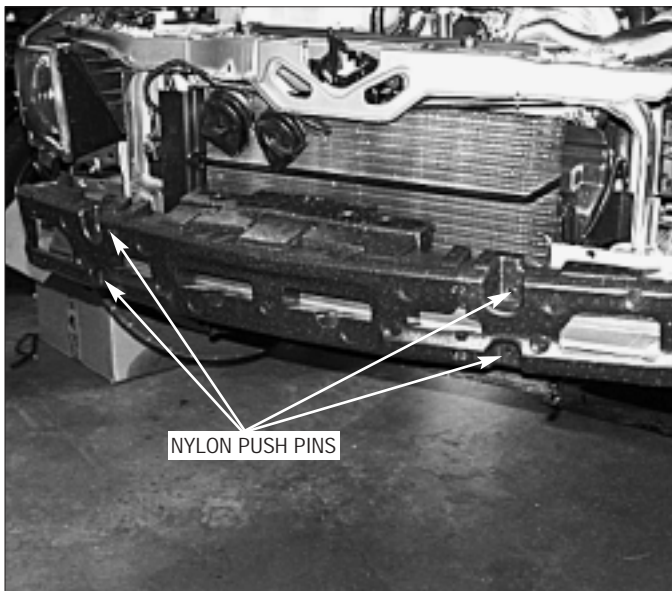

Fig. 3A-j

14. Remove four inner bolts of eight 13mm headed bolts retaining the metal bumper support. (See Fig. 3A-k.)

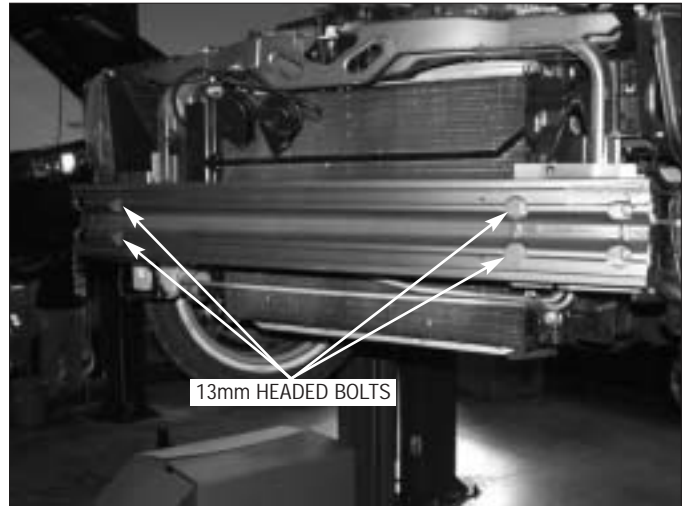

Fig. 3A-k

15. Replace the bolts previously removed with the four 8mm x 1.25" x 35mm long bolts and washers provided.
16. Install the four 2A017-036 spacers (two each side) to the bolts. (See Fig. 3A-l.)

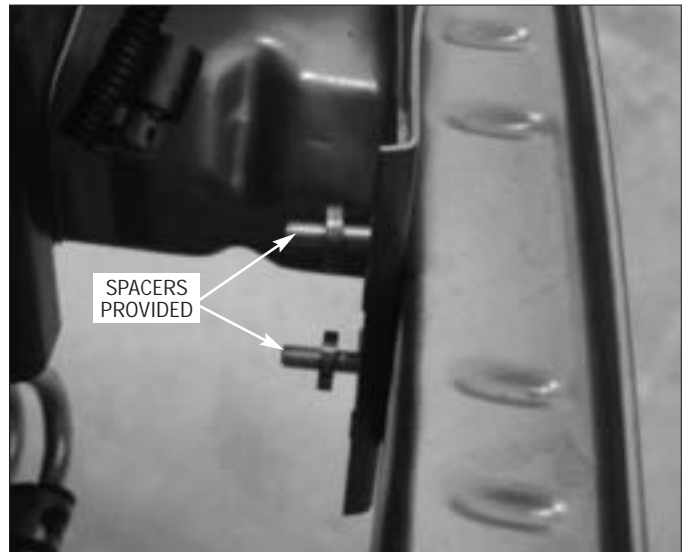

Fig. 3A-l

17. Replace the styrofoam bumper support using the factory retainers.

### 3. CHARGE AIR COOLER INSTALLATION, cont'd

#### B. CHARGE AIR COOLER ASSEMBLY

\*\*\* NOTE \*\*\*

Use Fig. 3B-a to aid in the next few steps

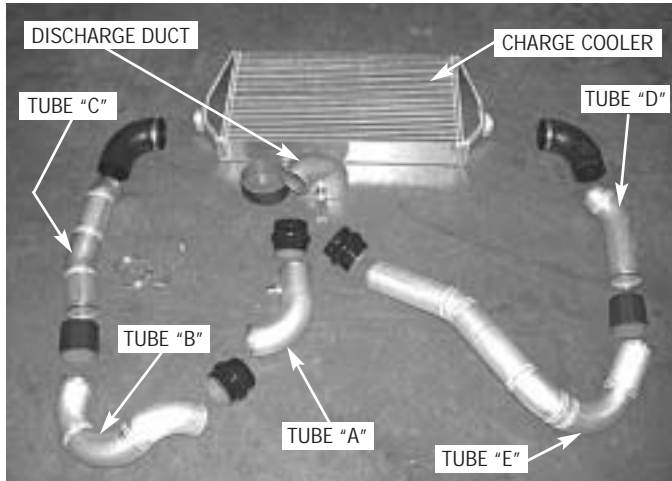

Fig. 3B-a

1. Locate the Charge Air Cooler assembly. Place the cooler onto the previously installed hardware, making sure the four spacers remain in place. Align the top of the cooler flush with the top of the styrofoam bumper support. Secure the cooler using the nuts and washers provided. (See Fig. 3-b.)

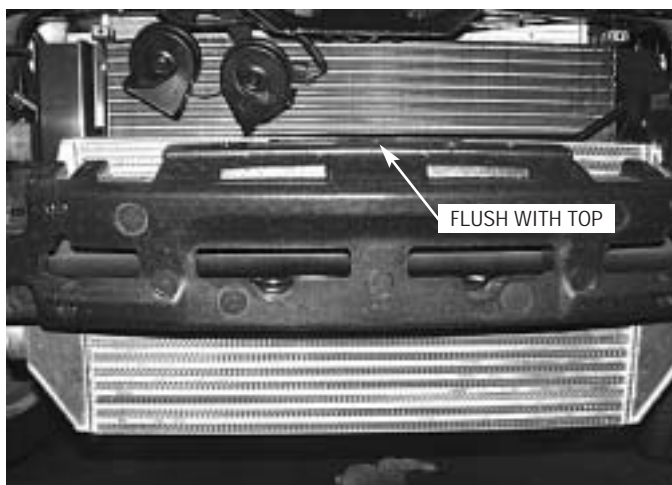

Fig. 3B-b

2. Loosely install the short ends of the two 90° rubber elbows onto each end of the charge cooler using the supplied #48 hose clamps. (See Fig. 3B-c.)

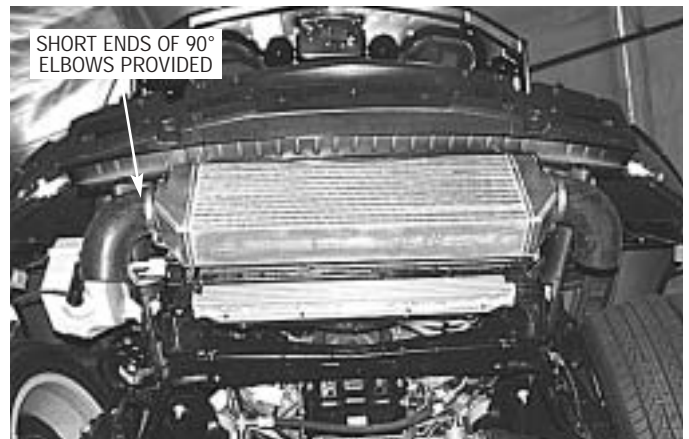

Fig. 3B-c

3. Using a 3" x 3" bump sleeve, 2.75"ID x 1" long sleeve, and two #48 hose clamps, loosely attach tube "A" to the supercharger discharge.

\*\*\* NOTE \*\*\*

The 2.75"ID x 1" long sleeve should be placed on the supercharger discharge first, then attach the 3" x 3" bump sleeve.

\*\*\* NOTE \*\*\*

The by-pass port should be facing the driver's side

4. Attach tube "B" using a second 3" x 3" bump sleeve and the provided #48 hose clamps to the open end of tube "A".

\*\*\* NOTE \*\*\*

For better duct clearance, rotate the power steering return fitting so that it points to the front of the vehicle. Use care not to damage the fitting or hose. If necessary, rotate the power steering line from the rack to the radiator closer to the frame. (See Fig. 3B-d.)

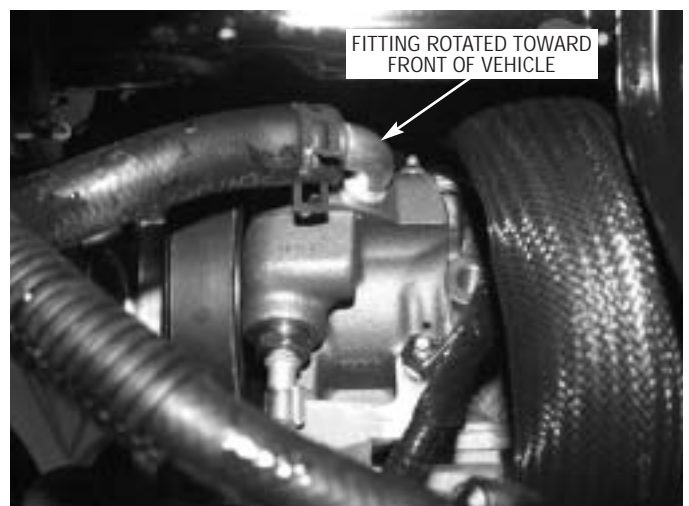

Fig. 3B-d

### 3. CHARGE AIR COOLER INSTALLATION, cont'd

5. Install the provided 3" x 3" sleeve and #48 hose clamps onto the open end of tube "B".
6. Using a 5/16-18 tap, tap the lower hole on the driver's and passenger's side core support. Locate the tube support brackets, 5/16-18 x 1/2" screws and washers. Loosely attach the tube support brackets to the core support. (See Fig. 3B-e, 3B-g.)

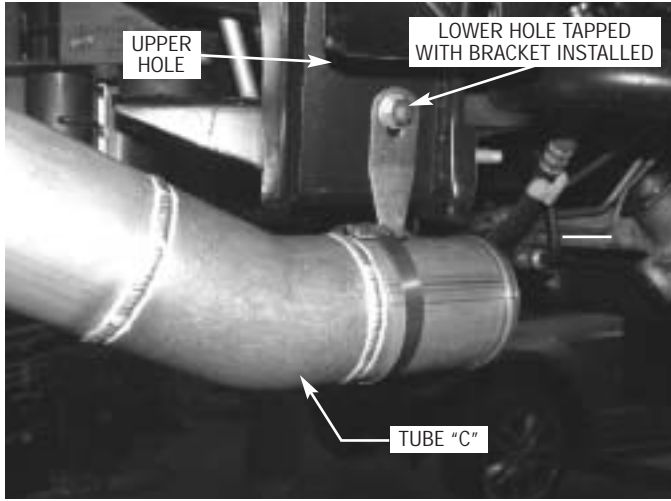

Fig. 3B-e | Driver's side

7. Install tube "C" between the 90° rubber elbow and the 3" x 3" sleeve previously installed on tube "B". Attach tube "C" to its support bracket using the #44 hose clamp. Tighten the clamp and bracket. Secure all hose connections to this point using the #48 hose clamps provided adjusting for best fit and clearance.
8. Install the short end of tube "D" into the open end of the passenger's side 90° rubber elbow previously install. (See Fig. 3B-f.)

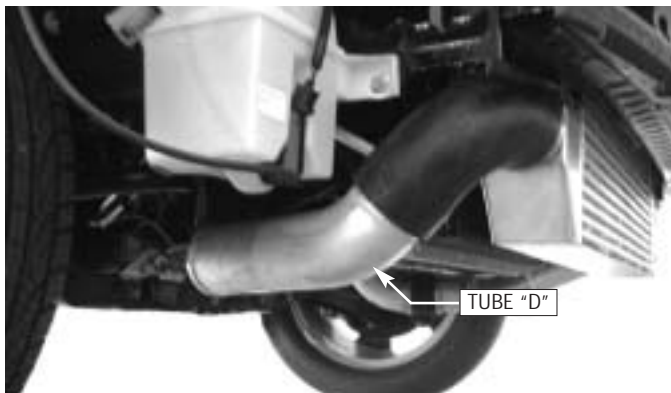

Fig. 3B-f

9. Attach a 3" x 3" sleeve and #48 hose clamps to the open end of tube "D".
10. Install the short end of tube "E" into the sleeve attached to tube "D". Secure the tube support bracket using the previously installed #48 hose clamp. (See Fig. 3B-g.)

\*\*\* NOTE \*\*\*

For better fit, the transmission cooler lines (if equipped) will need to be pushed upward slightly so that tube "E" will fit between them and the A/C compressor. (See Fig. 3B-g.)

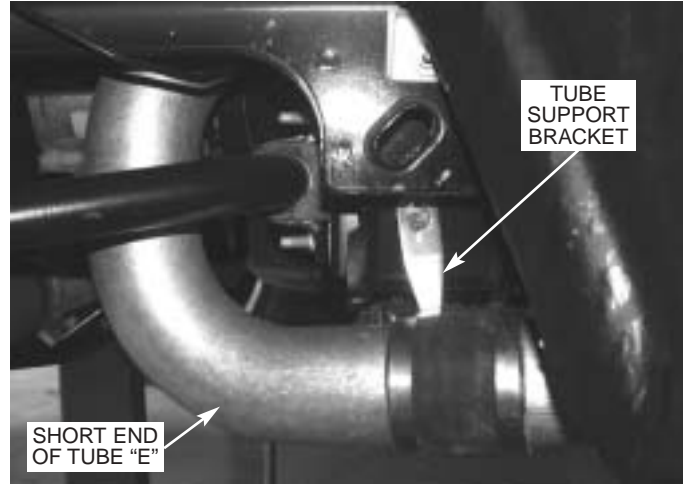

Fig. 3B-g | Passenger's side

11. Attach the cast discharge duct to the throttle body using the supplied 4.5" sleeve and #72 hose clamps.
12. Using the remaining 3" x 3" bump sleeve and #48 hose clamps, connect the long end of tube "E" to the cast discharge tube. (See Fig. 3B-h.)

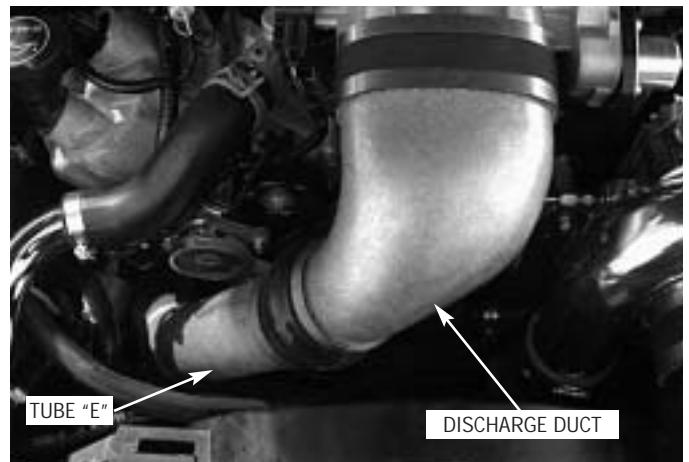

Fig. 3B-h

13. Secure all hose connections at this time, adjusting for best fit and clearance.

### 3. CHARGE AIR COOLER INSTALLATION, cont'd

#### C. COMPRESSOR BYPASS VALVE ASSEMBLY INSTALLATION

1. Bypass valve #1:
  - a. Cut a piece of the provided 1" heater hose approximately 3" long and secure it to the by-pass valve inlet (opposite the vacuum port) using the #16 hose clamps provided.
  - b. Locate the 1" molded rubber 90° elbow and cut approximately 6" from the long end and 1" from the short end. Attach the long end to the by-pass valve discharge and secure using the #16 hose clamps provided. (See Fig. 3C-a, 3C-d.)
  - c. Attach the open end of the 3" long hose to the by-pass port on tube "A" and secure using a #16 hose clamp. The open end of the 90° hose will be connected to the inlet duct in a later step. See Fig. 3C-d.)

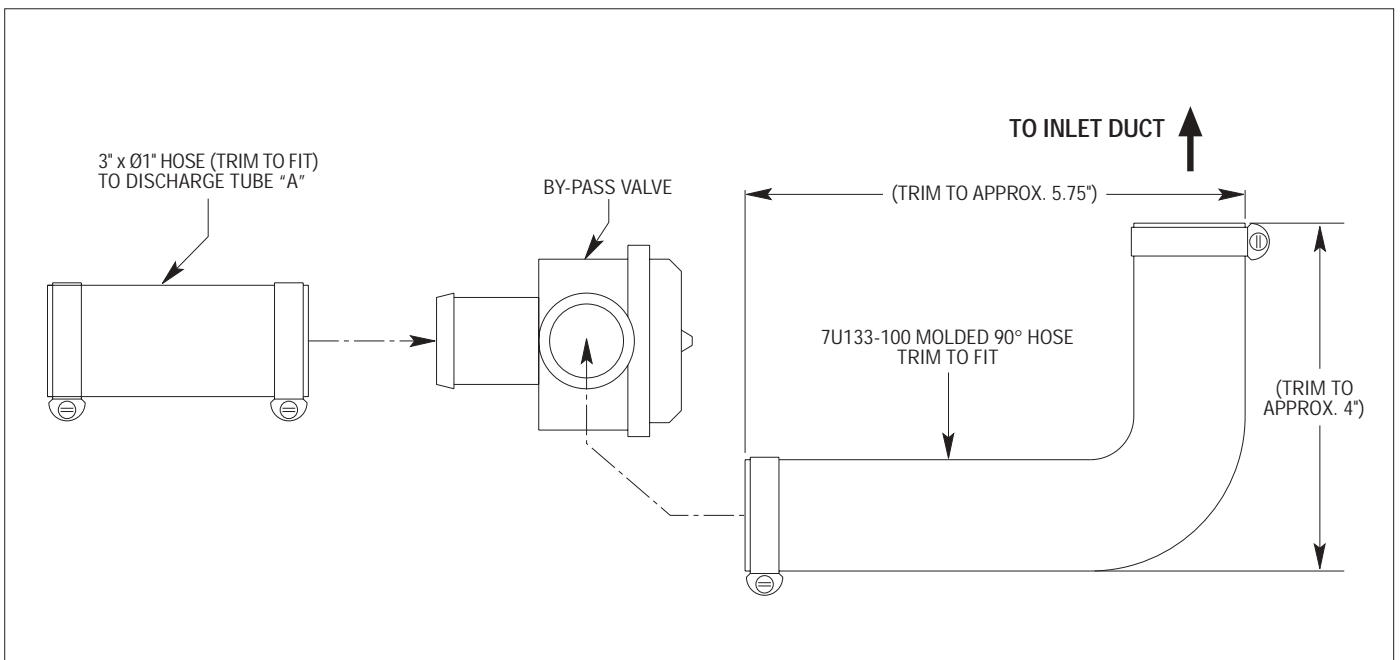

Fig. 3C-a



### 3. CHARGE AIR COOLER INSTALLATION, cont'd

- e. Attach a length of 5/32" vacuum hose to bypass valve #2 and route to the vacuum port of the fuel rail sensor.
- f. Cut a section of the factory hose and install the vacuum TEE that is provided. (See Fig. 3C-c.)

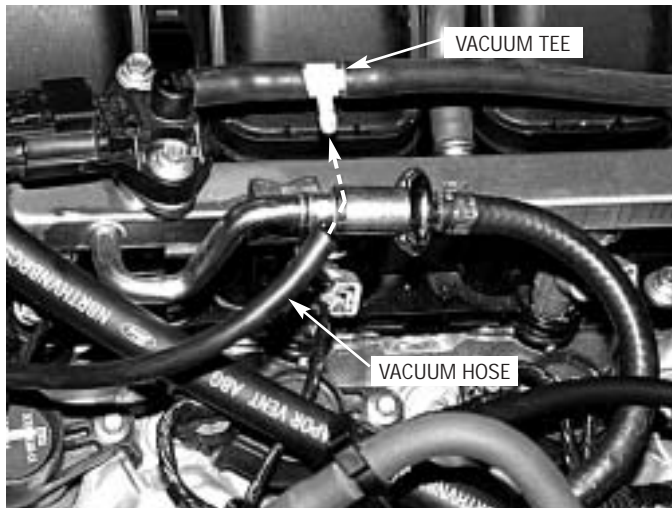

Fig. 3C-c

- g. Attach the vacuum hose from the bypass valve to the TEE.
- h. Attach a length of 5/32" vacuum hose to the previously installed bypass valve #1. Connect the open end to the previously installed vacuum line running to the fuel rail from bypass #2 using the TEE provided. (See Fig. 3C-d.)

**3. CHARGE AIR COOLER INSTALLATION, cont'd**

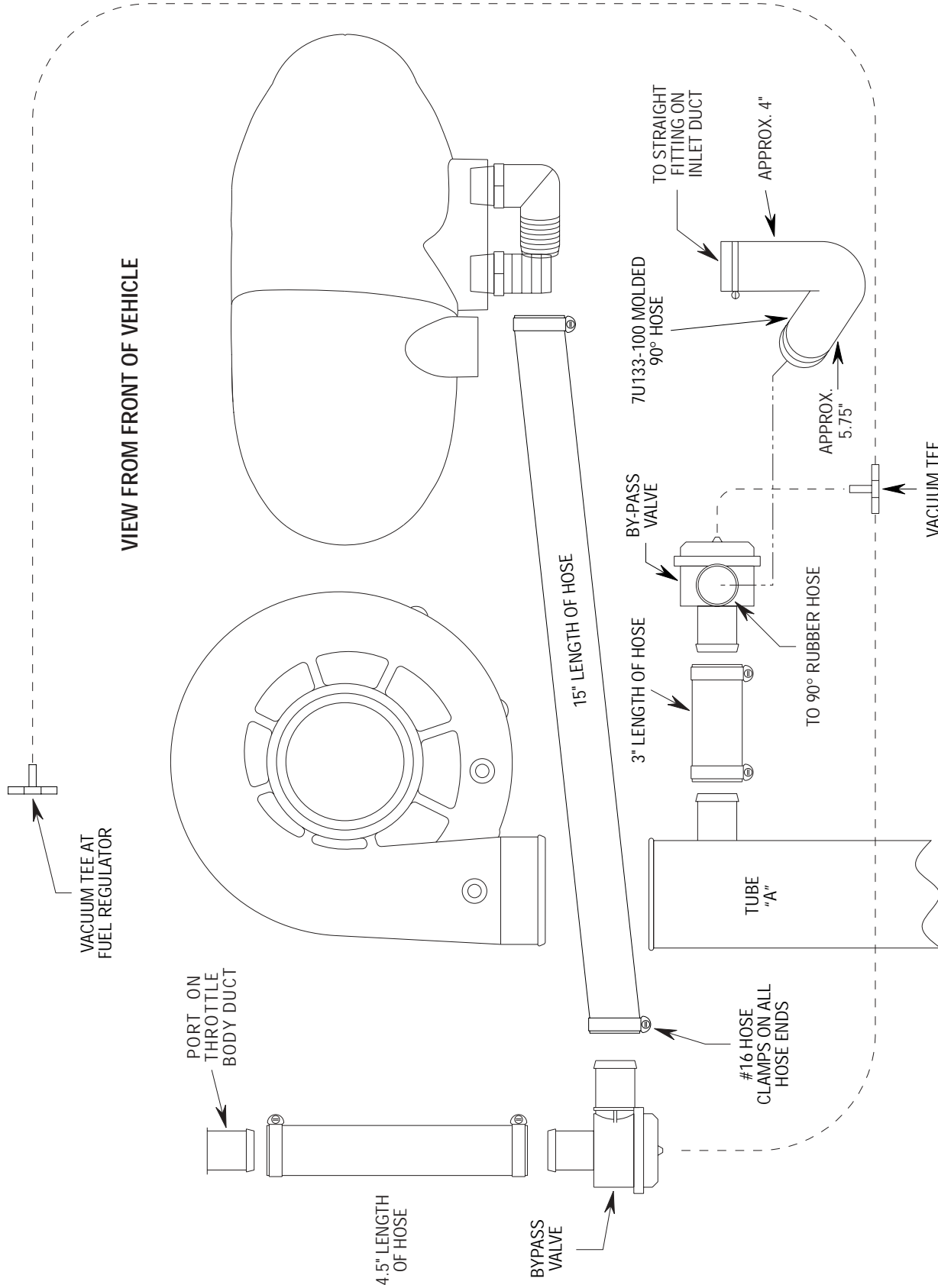

Fig. 3C-d

### 3. CHARGE AIR COOLER INSTALLATION, cont'd

#### D. WIRING HARNESS RELOCATION

1. On the passenger's side of the engine, attached to the valve cover, is a large wire harness. The harness will have to be relocated to gain clearance for the radiator overflow reservoir. (See Fig. 3D-a.)



Fig. 3D-a

2. Detach the wiring harness from the retaining clips and move the harness to the shock tower. Secure the harness to the A/C line with wire ties. (See Fig. 3D-b.)

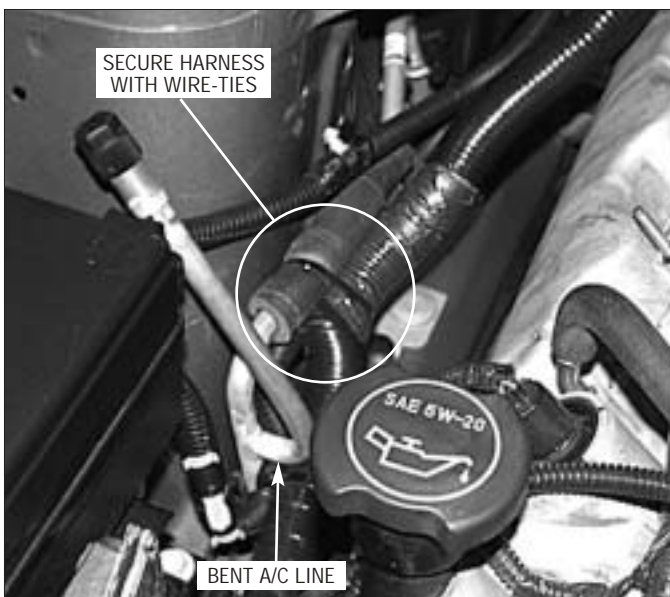

Fig. 3D-b

3. Remove the small clip retaining the small wiring harness to the shock tower. (See Fig. 3D-b.)
4. Attach the small harness to the large harness with wire ties.
5. To gain clearance for the coolant reservoir the A/C line will need to be bent slightly towards the passenger's side fender. (See Fig. 3D-b.)
6. Remove the 10mm headed screw retaining the ground strap to the bracket on the strut tower. (See Fig. 3D-c.)

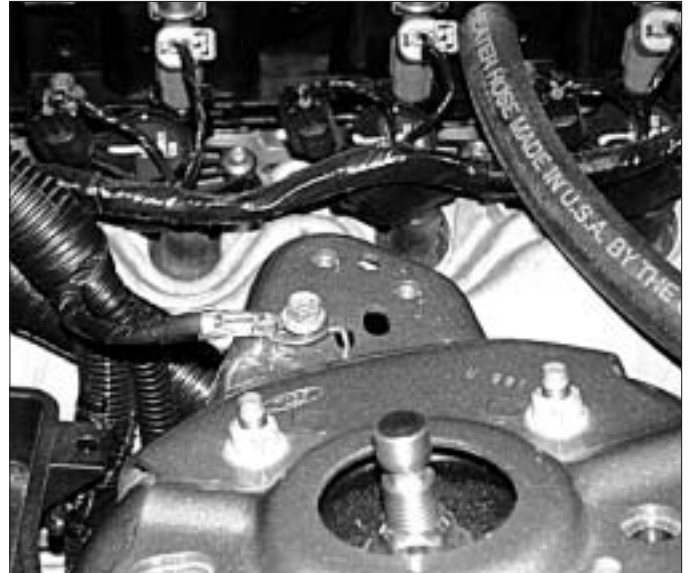

Fig. 3D-c

### 3. CHARGE AIR COOLER INSTALLATION, cont'd

#### E. ENGINE COOLANT RESERVOIR INSTALLATION

1. Locate assembly 8N155-080.
2. Attach the rear reservoir mounting bracket 4FU010-051 to the reservoir with the 1/4-20 x 3/4" long bolts and washers provided. (See Fig. 3E-a.)



Fig. 3E-a

3. Attach bracket 4FU010-061 to the front of the reservoir with the hardware provided. (See Fig. 3E-b.)

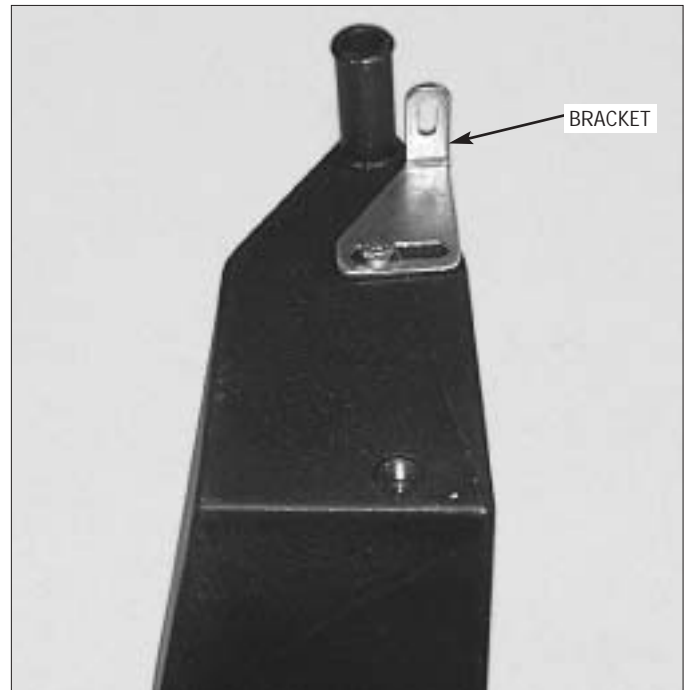

Fig. 3E-b

4. Locate and install 1/4"NPT x 3/8" barbed fitting in the tapped hole just above the previously installed mounting bracket. This hole may have to be opened using the appropriate drill bit. (See Fig. 3E-c.)

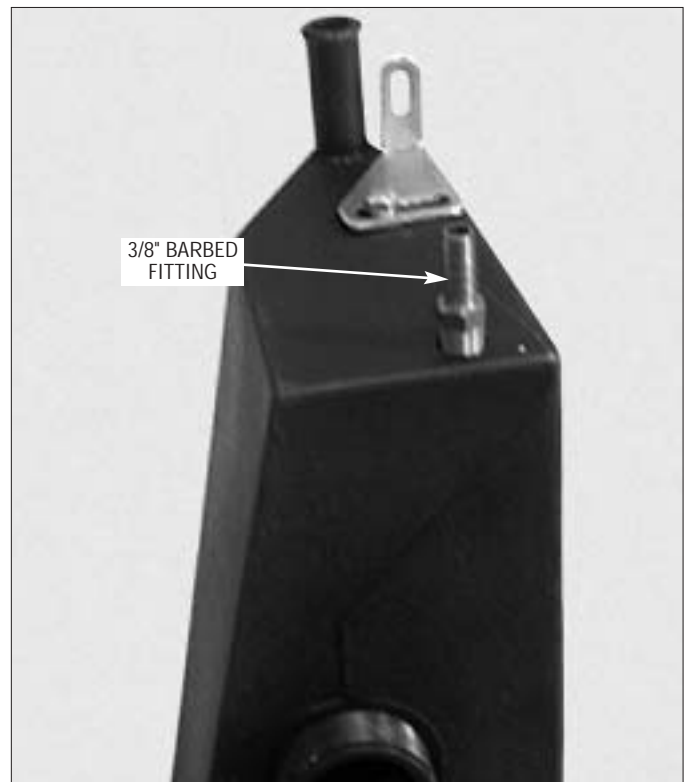

Fig. 3E-c

## 8. CHARGE AIR COOLER INSTALLATION, cont'd

5. Remove the 10mm headed bolt that secures the back of the ECU and the power distribution box. (See Fig. 3E-d.)

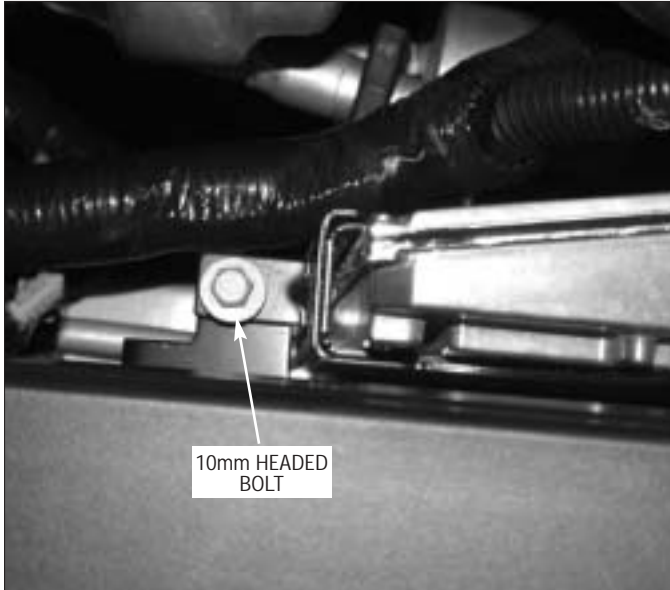

Fig. 3E-d

6. Install the coolant reservoir. Secure the front of the reservoir with the factory fastener removed previously. (See Fig. 3E-e.)

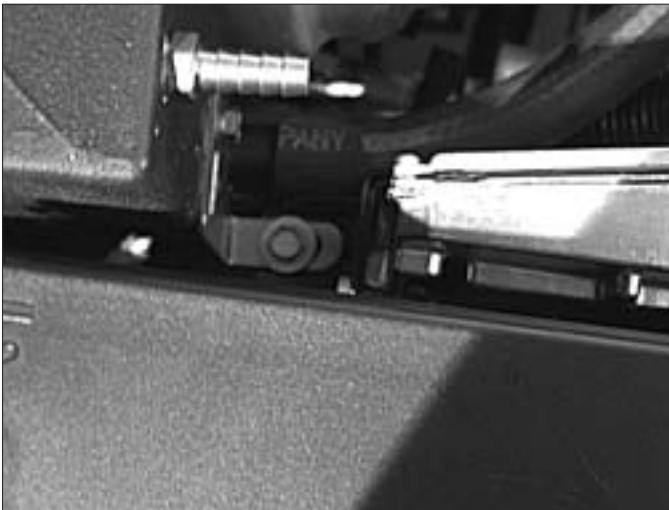

Fig. 3E-e

\*\*\* NOTE \*\*\*

Leave this bolt loose for final adjustment in a later step.

7. Attach the rear mounting bracket to the strut tower with the 6mm x 20mm long screws and washer provided. (See Fig. 3E-f.)

\*\*\* NOTE \*\*\*

Reinstall the factory ground wire with one of the 6mm screws and washers.

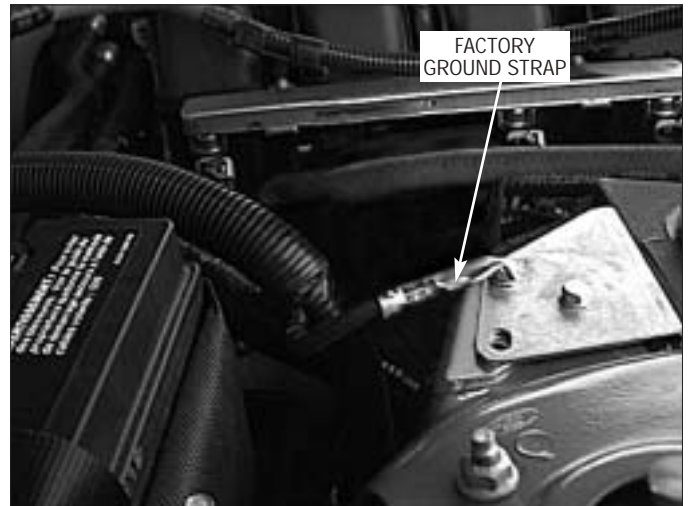

Fig. 3E-f

8. Attach a length of 3/4" hose (approximately 3') to the 3/4" bung on the front of the coolant reservoir. Route the hose to the 3/4" outlet on the thermostat housing secure the hose with the clamps provided. (See Fig. 3E-g.)

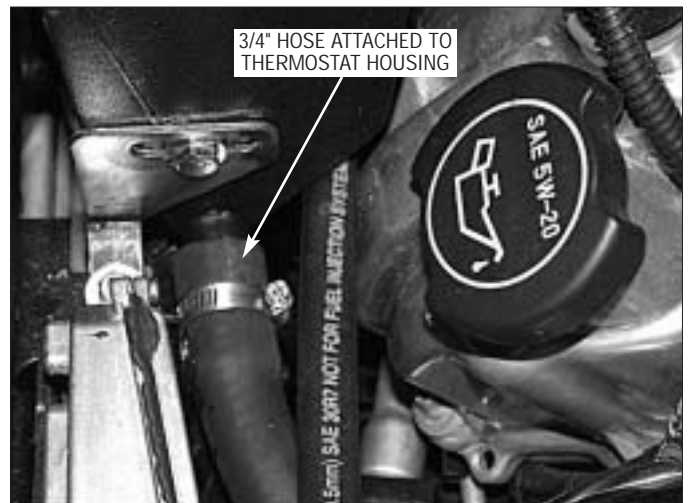

Fig. 3E-g

### 3. CHARGE AIR COOLER INSTALLATION, cont'd

9. Modify the small hose removed from the factory coolant overflow reservoir. By cutting the "S" bend off the hose end. (See Fig. 3E-h.)



Fig. 3E-h

10. Install a 3/8" union and a #17 stepless clamp. Secure the clamp. Using a length of 3/8" (approximately 30" long) hose that is provided, secure the hose to the union with a #17 stepless clamp. (See Fig. 3E-i.)



Fig. 3E-i

11. Route the overflow hose across the radiator and under the radiator retaining bracket to the 1/4"NPT x 3/8" hose barb fitting in the coolant reservoir securing with a clamp. (See Fig. 3E-j.)

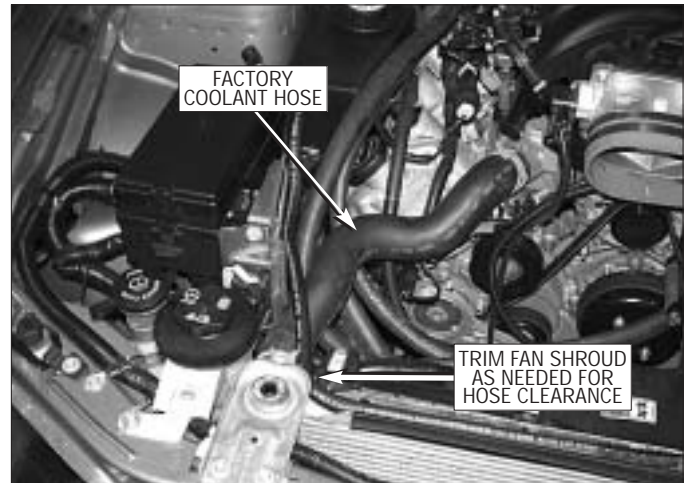

Fig. 3E-j

12. Check to see that all hose connections are secure.
13. Refill the coolant system using the factory coolant (if in good condition). Use the factory radiator cap saved during a previous step.
14. Reinstall the front bumper assembly including the foam inner bumper, all plastic splash panels and light connections in the reverse order removed.

*This Page Left Intentionally Blank*

# Section 4

## AIR INLET ASSEMBLY

### 4. AIR INLET ASSEMBLY

- A.** Remove two of the 3/8-16 x 1" bolts securing the supercharger in place. Install the air inlet support bracket and secure with the 3/8" bolts removed from the supercharger mounting plate. (See Fig. 4-a.)



Fig. 4-a

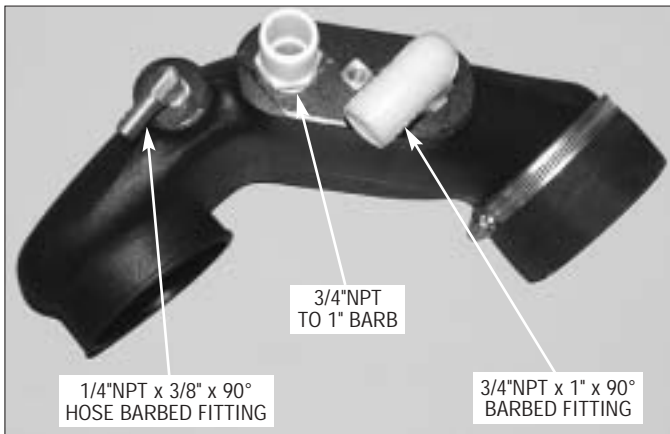

Fig. 4-b



Fig. 4-c

- B.** Attach the 4.0 x 3.5 reducer sleeve to the inlet duct. Secure the sleeves with the clamps provided. (See Fig. 4-c.)
- C.** Using a 7/8" hole saw, drill the secondary bypass provision. Be careful not to damage the plastic threads.
- D.** Apply a small amount of pipe sealant to the supplied 3/4"NPT to 1" straight barb fitting. Install the fitting in the previously drilled hole. (See Fig. 4-b.)
- E.** Attach the open end of the previously installed 1" x 90° hose to the 1" straight barb fitting and secure with a #16 hose clamp provided.

#### 4. AIR INLET ASSEMBLY, cont'd

- F. Attach the 1" bypass outlet hose to the 90° plastic fitting and secure the hose with a # 16 hose clamp.
- G. Re-attach the 3/8" hose to the 1/4"NPT x 3/8" hose x 90° fitting installed in the inlet duct.
- H. Re-install the duct to the inlet of the supercharger and secure in place with the clamps previously removed
- I. Install the 180° duct and the MAF sensor with filter to the inlet duct leading to the Supercharger.(See Figs. 4-d, 4-e.) Clock the MAF exactly as shown in the figure.
- J. Secure the rear clamp at the inlet duct union to the previously installed support bracket. (See Fig. 4-e).



Fig. 4-d

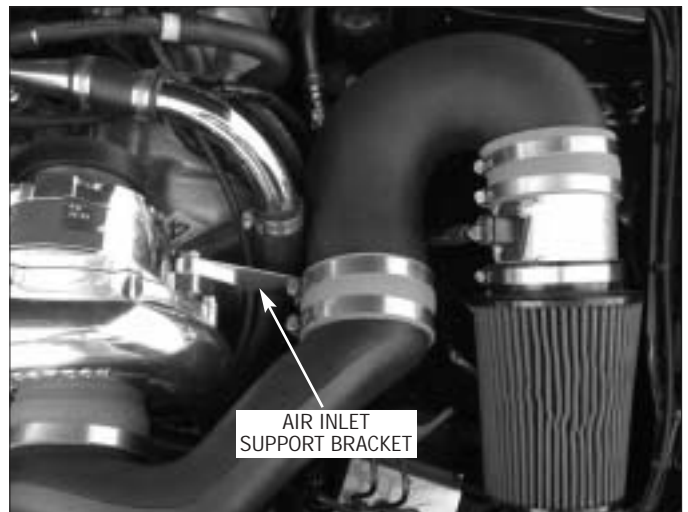

Fig. 4-e

#### K. MAF Interface Adapter Installation.

1. If in the event you have received a MAF Interface Adapter that is not a "plug in" unit, it will be necessary to modify the adapter as outlined in steps 2 & 3 below. Otherwise, plug the MAF interface adapter between the factory MAF and the MAF harness connector and ignore steps 2 & 3 below.
2. Remove the connector that is attached to the MAF Interface Adapter leave approximately 2-3" of wire measured from the plug end.
3. Remove the factory MAF sensor plug from the car leaving an adequate length of wire to be soldered to the wires of the MAF Interface Adapter. (Approximately 2-3".)

\*\*\* **NOTE** \*\*\*

*It is strongly recommended that the wires be soldered. Temporary solderless connectors have been provided in case you are unable to solder.*

#### 4. AIR INLET ASSEMBLY, cont'd

4. Install the MAF Interface Adapter to the wires of the factory harness.
5. Install the factory MAF sensor connector to the MAF adapter in place of the original MAF adapter connector.
6. Refer to the diagram provided for wire colors and there locations.
7. Remove the small red cover in the middle of the supplied MAF Interface Adapter box.
8. Verify that the MAF Interface Adapter box is set on number "2".
9. If you find that the MAF Interface Adapter box is not set, use the tool that is provided with the MAF Interface Adapter box and set to number "2".
10. Replace the cover and secure the MAF Interface Adapter box away from hot or moving parts with nylon ties.

\*\*\* NOTE \*\*\*

***It is critical*** that the MAF Interface Adapter box be set on number "2". The calibration that is provided with this kit has been created to work at this setting. Any change to the MAF Interface Adapter box by setting it to a higher or lower number could cause damage to the engine.

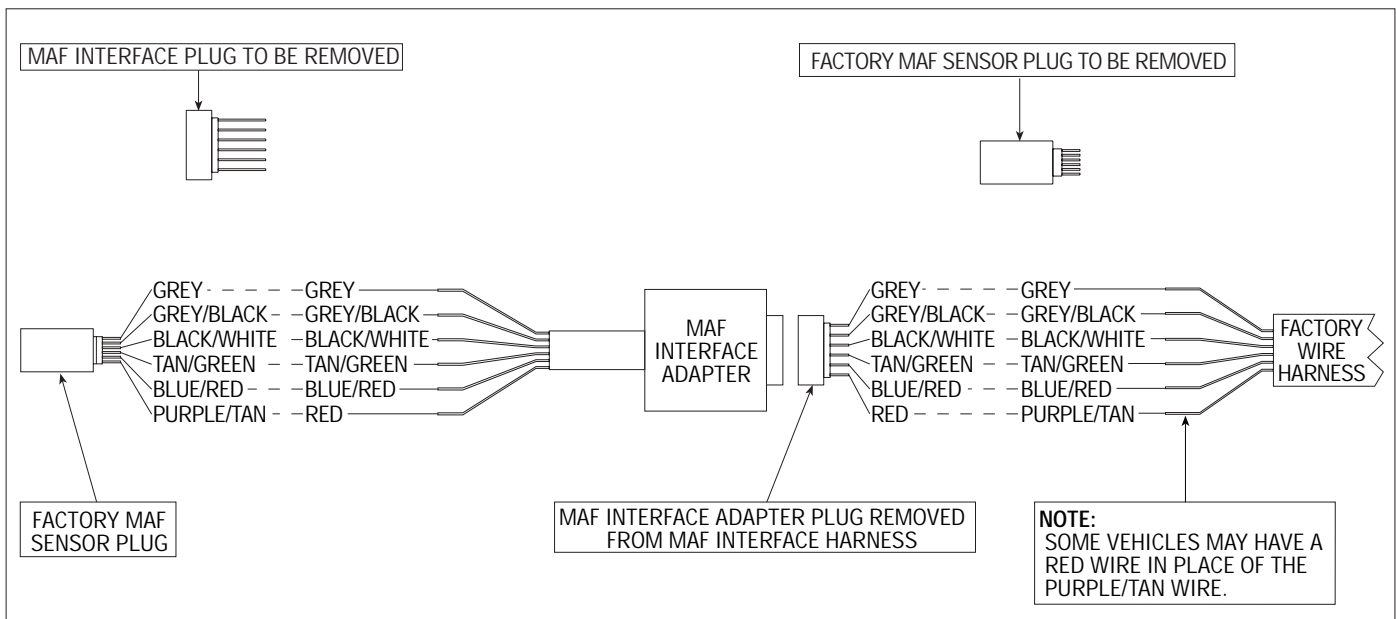

Fig. 4-f c  
(FOR H.O. Kits Only — Hard wire schematic for MAF Interface Adapter.)

*This Page Left Intentionally Blank*

---

# Section 5

## FINAL CHECK

---

### 5. FINAL CHECK

---

**\*\*\* NOTE \*\*\***

*Do not attempt to operate the vehicle until ALL components are installed and ALL operations are completed including the final check.*

---

- A.** Check all fittings, hose and clamps for tightness and leaks. Make sure all wires and lines are properly secure with clamps or tie-wraps.
- B.** Make sure all wires and hoses are routed away from hot, moving or sharp objects.
- C. Custom Tuning:** This kit requires custom ECM calibration before the vehicle is to be driven at any throttle opening greater than 50%. Calibration by a competent tuner with a wide band O<sub>2</sub> sensor and timing monitoring equipment is required.
- D.** Test drive the vehicle.
- E.** Always listen carefully for engine detonation. Discontinue heavy throttle usage if detonation is heard.



**Paxton Automotive . 1300 Beacon Place . Oxnard CA 93033  
805 604-1336 . FAX • 805 604-1337**